



# Smart Managed Solar Industrial PoE Switch

## Quick Start Guide



See Far, Go Further



# Preface

## Applicable Models

This manual is applicable to the smart managed solar industrial PoE switch.

## Symbol Conventions

The symbols that may be found in this document are defined as follows.

Symbol	Description
 <b>Note</b>	Provides additional information to emphasize or supplement important points of the main text.
 <b>Caution</b>	Indicates a potentially hazardous situation, which if not avoided, could result in equipment damage, data loss, performance degradation, or unexpected results.
 <b>Danger</b>	Indicates a hazard with a high level of risk, which if not avoided, will result in death or serious injury.

## Safety Information

Please read all the safety information carefully before using.

### Electricity

- In the use of the product, you must be in strict compliance with the electrical safety regulations of the nation and region.
- Provide a surge suppressor at the inlet opening of the device under special conditions such as the mountain top, iron tower, and forest.
- **CAUTION:** If the fuse of the device can be replaced, replace it only with the same type and rating of fuse to reduce the risk of fire or electric shock.

### Battery



#### ● **WARNING**

1. Do not ingest battery. Chemical Burn Hazard!
2. Keep new and used batteries away from children.
3. If the battery compartment does not close securely, stop using the product and keep it away from children.
4. If you think batteries might have been swallowed or placed inside any part of the body, seek immediate medical attention.
5. **CAUTION:** Risk of explosion if the battery is replaced by an incorrect type.
6. Improper replacement of the battery with an incorrect type may defeat a safeguard (for example, in the case of some lithium battery types).
7. Do not dispose of the battery into fire or a hot oven, or mechanically crush or cut the battery, which may result in an explosion.
8. Do not leave the battery in an extremely high temperature surrounding environment, which may result in an explosion or the leakage of flammable liquid or gas.

9. Do not subject the battery to extremely low air pressure, which may result in an explosion or the leakage of flammable liquid or gas.
  10. Dispose of used batteries according to the instructions.
- For the battery with + and - signs, + identifies the positive terminals of the device which is used with or generates direct current, and - identifies the negative terminals of the device which is used with or generates direct current.

### Fire Prevention

- No naked flame sources, such as lighted candles, should be placed on the equipment.
- The power output port of the device does not comply with Limited Power Source. The device which is provided power by this port shall be equipped with a fire-retardant enclosure.

### Hot Surface Prevention

- For the device with sticker  or , pay attention to the following cautions:

CAUTION: Hot parts! Do not touch. Burned fingers when handling the parts. Wait one-half hour after switching off before handling the parts.

This sticker is to indicate that the marked item can be hot and should not be touched without taking care. For device with this sticker, this device is intended for installation in a restricted access location, access can only be gained by service persons or by users who have been instructed about the reasons for the restrictions applied to the location and about any precautions that shall be taken.

### Installation

- Do not install devices for professional use in locations where children are likely to appear.
- Install the device according to the instructions in Quick Start Guide. To prevent injury, this device must be securely attached to the installation surface in accordance with the installation instructions.
- Do not touch the sharp edges or corners.
- CAUTION: If the bracket is designed for a specific device model of our company, use the bracket with the corresponding device only. Use with other devices may result in instability and cause injury. Refer to the device datasheet for details.
- CAUTION: If the device needs to be installed with a specific bracket of our company, use the corresponding bracket only. Use others (such as carts, stands, and carriers) may result in instability and cause injury. Refer to the device datasheet for bracket model details.

### Transportation

- Keep the device in original or similar packaging while transporting it.

### Maintenance

- If the product does not work properly, please contact your dealer or the nearest service center. We shall not assume any responsibility for problems caused by unauthorized repair or maintenance. A few device components (e.g., electrolytic capacitor) require regular replacement. The average lifespan varies, so periodic checking is recommended. Contact your dealer for details.

### Cleaning

- Please use a soft and dry cloth when cleaning inside and outside surfaces of the product cover. Do not use alkaline detergents.

### **Using Environment**

- Make sure the running environment meets the requirement of the device. DO NOT place the device in extremely hot, cold, dusty or damp locations, and do not expose it to high electromagnetic radiation. For temperature and humidity requirements, refer to device specification for details.

### **Emergency**

- If smoke, odor, or noise arises from the device, immediately turn off the power, unplug the power cable, and contact the service center.

# 1 Introduction

## 1.1 Product Introduction

DS-3T1506HP-EI-UPS is a smart managed solar industrial PoE switch developed by Hikvision. It can be charged by solar power for energy conservation so as to power IP cameras (IPCs), wireless bridges, or wireless access points (APs) in remote areas in a cost-effective way. The device features 4 gigabit PoE RJ45 ports and 2 gigabit SFP fiber optical ports, among which ports 3 and 4 provide passive 24 V/54 V power supply options. It is especially suitable for large-scale application scenarios such as national parks, highways, forests, deserts, etc.

## 1.2 Packing List

Please check if the package is damaged first. If the package is intact, unpack it and check whether the accessories provided with the product are available by referring to the packing list. Then, you can continue to install the device.

Table 1-1 Packing List

Accessory	Quantity
Switch	× 1
Wall Mount Ear Kit	× 1
 Note A wall mount ear kit contains 2 wall mount ears and 5 M3 screws.	
Quick Start Guide	× 1
Regulatory Compliance and Safety Information	× 1

## 1.3 Appearance

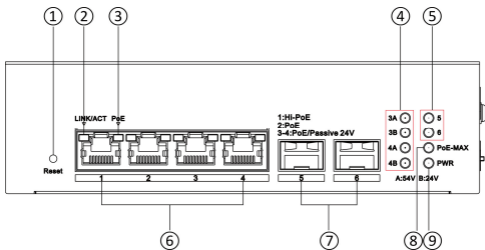

Figure 1-1 Front Panel

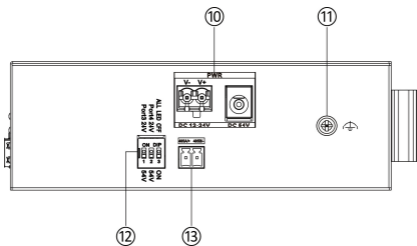





Figure 1-2 Side Panel

Table 1-2 Port/Indicator Description

No.	Port/Indicator	Description
①	Reset Button	Press and hold the reset button for more than 5 seconds to restore all the configurations of the switch to default settings.
②	LINK/ACT Indicator	<ul style="list-style-type: none"> <li>● Solid on: The port is connected.</li> <li>● Flashing: The port is transmitting data.</li> <li>● Unlit: The port is disconnected or connection is abnormal.</li> </ul>
③	PoE Indicator	<ul style="list-style-type: none"> <li>● Solid on: The switch supplies power to a powered device (PD) normally.</li> <li>● Unlit: The switch is disconnected from a PD or power supply is abnormal.</li> </ul>
④	Function Indicator	<p>3A:</p> <ul style="list-style-type: none"> <li>● Solid on: 54 V standard PoE is enabled for port 3.</li> <li>● Unlit: 54 V standard PoE is disabled for port 3.</li> </ul> <p>3B:</p> <ul style="list-style-type: none"> <li>● Solid on: 24 V non-standard PoE is enabled for port 3.</li> <li>● Unlit: 24 V non-standard PoE is disabled for port 3.</li> </ul> <p>4A:</p> <ul style="list-style-type: none"> <li>● Solid on: 54 V standard PoE is enabled for port 4.</li> <li>● Unlit: 54 V standard PoE is disabled for port 4.</li> </ul> <p>4B:</p> <ul style="list-style-type: none"> <li>● Solid on: 24 V non-standard PoE is enabled for port 4.</li> <li>● Unlit: 24 V non-standard PoE is disabled for port 4.</li> </ul>
⑤	Gigabit SFP Fiber Optical Port Indicator	<ul style="list-style-type: none"> <li>● Solid on: The gigabit SFP fiber optical port is connected.</li> <li>● Flashing: The gigabit SFP fiber optical port is transmitting data.</li> <li>● Unlit: The gigabit SFP fiber optical port is disconnected or connection is abnormal.</li> </ul>

No.	Port/Indicator	Description
⑥	Gigabit PoE RJ45 Port	<p>Used for connection to a PD via a network cable.</p> <hr/>  <b>Note</b> Port 1 of the switch is a Hi-PoE RJ45 port, which can be connected to a high-power device.
⑦	Gigabit SFP Fiber Optical Port	Used for connection to another device via an optical fiber when plugged into with an optical module.
⑧	PoE-MAX Indicator	<ul style="list-style-type: none"> <li>● Solid on: The output power of the switch is about to reach or has reached the upper limit. The power supply may be abnormal if more devices are connected.</li> <li>● Unlit: The switch supplies power to a PD normally and its output power does not reach the upper limit.</li> </ul> <hr/>  <b>Note</b> The PoE-MAX indicator will be unlit in 5 seconds after the output power of the switch returns to normal.
⑨	PWR Indicator	<ul style="list-style-type: none"> <li>● Solid on: The switch is powered on normally.</li> <li>● Unlit: No power supply is connected or power supply is abnormal.</li> </ul>
⑩	Power Supply	<p>Select DC 54 V for normal power input or DC 12-24 V for solar power input as required.</p> <ul style="list-style-type: none"> <li>● DC 54 V: Use a self-prepared power cord and power adapter to connect the switch to a power socket.</li> <li>● DC 12-24 V: Use two self-prepared power cords to connect the DC positive electrode to the battery positive electrode and the DC negative electrode to the battery negative electrode respectively.</li> </ul>
⑪	Grounding Terminal	Used for connection to the grounding cable to protect the switch from lightning.
⑫	DIP Switch	<p>1 (24 V/54 V for port 3):</p> <ul style="list-style-type: none"> <li>● When the DIP switch 1 is set to <b>Port3 24V</b>, port 3 can be compatible with 24 V forced PoE powered devices, such as wireless bridges.</li> <li>● When the DIP switch 1 is set to <b>54V</b>, port 3 only supplies power</li> </ul>

No.	Port/Indicator	Description
		<p>to IEEE 802.3af/at PoE powered devices, such as IPCs.</p> <p>2 (24 V/54 V for port 4):</p> <ul style="list-style-type: none"> <li>When the DIP switch 2 is set to <b>Port4 24V</b>, port 4 can be compatible with 24 V forced PoE powered devices, such as wireless bridges.</li> <li>When the DIP switch 2 is set to <b>54V</b>, port 4 only supplies power to IEEE 802.3af/at PoE powered devices, such as IPCs.</li> </ul> <p>3 (All indicators off/on):</p> <ul style="list-style-type: none"> <li>When the DIP switch 3 is set to <b>ALL LED OFF</b>, all indicators on the switch except the PWR indicator are unlit to save power.</li> <li>When the DIP switch 3 is set to <b>ON</b>, all indicators on the switch are solid on.</li> </ul>
⑬	RS485 interface	<p>Reserved for the switch to acquire battery information, such as battery voltage, current, state of charge (SOC), etc.</p> <hr/> <p> <b>Note</b></p> <p>Only battery information of the recommended optional solar batteries can be acquired. For details, please refer to the optional accessory section in the datasheet.</p>

## 2 Installation

Please select an appropriate installation method according to the actual needs.

### Note

The following figures are for illustration only. The actual device prevails.

#### Before You Start

- Ensure that the desktop, wall, or rail is stable and firm enough.
- Keep the room well-ventilated. Keep at least 10 cm distance around the device for heat dissipation.

### 2.1 Desktop Placement

Place the device on the desk.

### 2.2 Wall-Mounted Installation

#### Before You Start

Use a screwdriver to remove the DIN rail-mounted unit on the device body.

#### Steps

1. Fix the wall mount ears to the device with M3 screws provided in package.
2. Use self-prepared M4 screws to fix the device onto the wall.

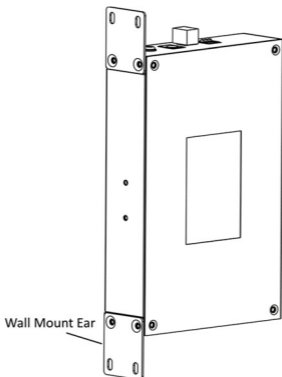

Figure 2-1 Wall-Mounted Installation

## 2.3 Rail-Mounted Installation

### Steps

1. Fix the clip to the device.
2. Insert the end of the DIN rail-mounted unit into the notch under the clip.

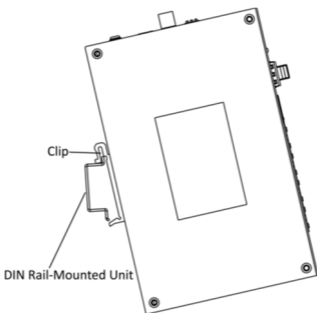

Figure 2-2 Rail-Mounted Installation

3. Press the DIN rail-mounted unit in quickly.
4. Optional: Use screws to fix the DIN rail-mounted unit onto the device.

## 3 Wiring

### 3.1 Connect Grounding Cable

Grounding is used to quickly release overvoltage and overcurrent induced by lightning on the device, and to protect personal safety. Select an appropriate grounding method according to the installation conditions.

## Note

The following figures are for your reference only. The actual device prevails.

### 3.1.1 With Grounding Bar

If a grounding bar is available at the installation site, follow the steps below.

#### Steps

1. Connect one end of the grounding cable to the binding post on the grounding bar.
2. Connect the other end of the grounding cable to the grounding terminal of the device and tighten the screw.

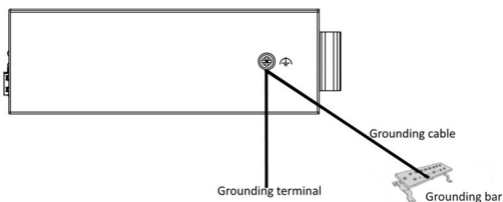

Figure 3-1 Grounding with Grounding Bar

### 3.1.2 Without Grounding Bar

If there is no grounding bar but the earth is nearby and the grounding body is allowed to be buried, follow the steps below.

#### Steps

1. Bury an angle steel or steel pipe ( $\geq 0.5$  m) into the earth.
2. Weld one end of the grounding cable to the angle steel or steel pipe and embalm the welding point via electroplating or coating.
3. Connect the other end of the grounding cable to the grounding terminal.

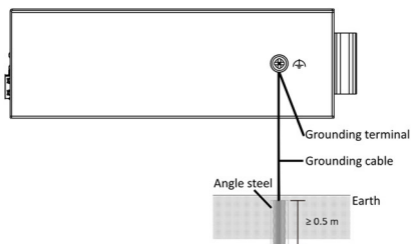

Figure 3-2 Grounding with Angle Steel

## 3.2 Connect RJ45 Port

Use a network cable to connect the device to the RJ45 port of a peer device such as IPC, network video recorder (NVR), switch, etc.

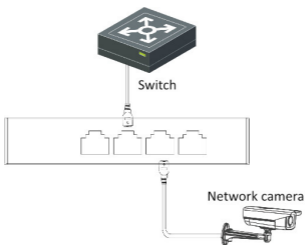

Figure 3-3 RJ45 Port Connection

### 3.3 Connect SFP Fiber Optical Port

Connect the device to a peer device through an optical fiber connecting SFP optical modules plugged into SFP fiber optical ports respectively.

#### Steps

#### ! Caution

- Single-fiber optical modules need to be paired for use.
- Do not bend an optical fiber (curvature radius  $\geq 10$  cm) overly.
- Do not look directly at an optical fiber connector because the laser generated is harmful to eyes.

1. Connect the two paired SFP optical modules with an optical fiber.
2. Hold the SFP optical module from one side, and smoothly plug it into the device along the SFP port slot until the optical module and the device are closely attached.
3. After powering on the device, check the status of the optical port indicator.
  - If the indicator is lit, the link is connected.
  - If the indicator is unlit, the link is disconnected. Check the line, and make sure that the peer device has been enabled.

## 4 Typical Application

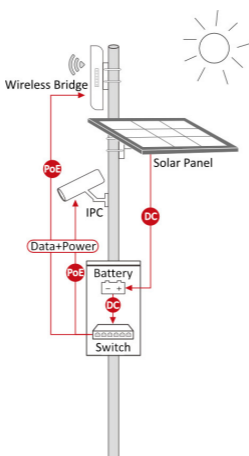

Figure 4-1 Solar Power System

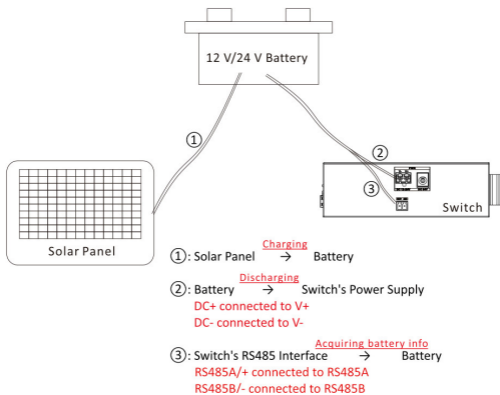

Figure 4-2 Power Connection

Follow the steps below to set up power connections of the solar power system.

### Steps

1. Place the grounded switch and battery in a proper enclosure.
2. Connect the battery to the switch.

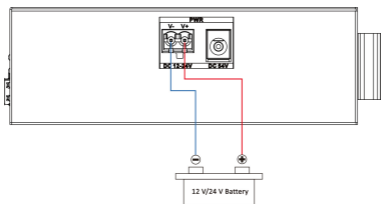

Figure 4-3 Battery Connection

- a. Connect the positive electrode of the battery (labelled as **DC+** on the cable) to the terminal for the positive electrode (**V+**) on the switch.
  - b. Connect the negative electrode of the battery (labelled as **DC-** on the cable) to the terminal for the negative electrode (**V-**) on the switch.
  - c. Check the status of the PWR indicator. Solid on means that the switch is powered on normally.
  - d. (Optional) Connect the RS485 interface of the battery cable to that on the switch (**RS485A** connected to **RS485A/+**, **RS485B** connected to **RS485B/-**) so that the switch can acquire battery information directly.
3. Connect the power cable of the PV panel to that of the battery so as to charge the battery with solar energy.
  4. Connect PoE powered devices to the switch for both PoE power supply and data transmission.

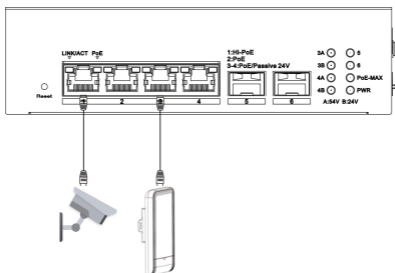

Figure 4-4 PD Connection

- a. Connect an IEEE 802.3af/at PoE powered device, such as IPC, to port 1 or port 2 of the switch.
- b. Connect a 24 V forced PoE powered device, such as wireless bridge, to port 3 or port 4 of the switch.

 Note

DIP switch 1 or DIP switch 2 must be set to **24V** so that port 3 or port 4 can be compatible with a 24 V forced PoE powered device.

- c. Check the status of corresponding PoE and LINK/ACT indicators. If the PoE powered device such as IPC or wireless bridge is powered on, the PoE indicator will turn solid on, and the LINK/ACT indicator will turn solid on or flashing for a successful connection or data transmission.

 Note

- Please use Cat. 5/5e or above network cables, and the recommended maximum distance is 100 meters.
- If the network devices are installed outdoors, please consider to install a lightning arrester.

## 5 Device Management

### 5.1 On Hik-Partner Pro App

The Hik-Partner Pro app supports batch device activation, network topology drawing, device configuration, system maintenance, etc., as well as power saving management.

**Steps**

1. Install the Hik-Partner Pro app.



Figure 5-1 Scan and Download HPP

2. Connect your phone to a Wi-Fi network. If you cannot connect to a Wi-Fi network, use a USB-C RJ45 adapter to connect your phone to a LAN.

 **Note**

Make sure your phone and the devices in your networking (such as the switch, wireless bridge, and IPC) are on the same LAN and are not activated.

3. Batch activate devices in your networking plan.
  - a. Open the Hik-Partner Pro app, and tap **Activate** to batch activate new devices found.
  - b. Enter the password for user **admin** and verification code, and tap **Next**.
  - c. Wait until the devices are activated, and then tap **Complete**.
4. Add devices to a site.
  - a. Create a new personal or team site, or select an existing site.
  - b. Select the desired devices, and tap **OK** to add the devices to the site.
5. Optional: Tap **Transfer** to hand over the site to the customer.
6. Check the battery information, including state of charge, remaining battery, battery level of last 1 day or 7 days, etc.

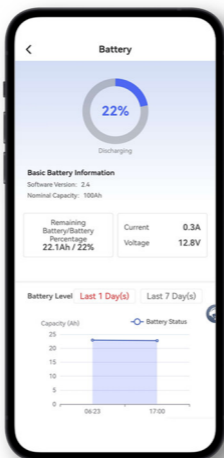

Figure 5-2 Check Battery Information

Table 5-1 Navigation Path

No.	Steps
1	a. Select a site to which the devices are added. b. Tap <b>⋮</b> → <b>Battery</b> of the corresponding device on the <b>Devices</b> tab page.
2	a. Select a site to which the devices are added. b. Tap the corresponding device on the <b>Devices</b> tab page to enter the device details page. c. Tap <b>⚙️</b> → <b>Battery</b> .
3	a. Select a site to which the devices are added. b. Tap the corresponding device on the <b>Devices</b> tab page to enter the device details page. c. Tap <b>⚙️</b> → <b>Advanced Settings</b> → <b>Power Saving Management</b> → <b>Battery</b> .

7. Configure basic mode, advanced mode, or low power mode for your power saving plan.

- Tap **⚙️** → **Advanced Settings** → **Power Saving Management** → **Power Saving Plan**.
- Add basic or advanced power-saving rules, or enable low power mode as prompted according to your actual networking requirements.

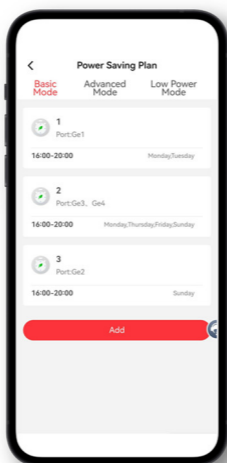

Table 5-3 Configure Power Saving Plan

Table 5-2 Power Saving Mode

Mode	Description
Basic Mode	Add basic power-saving rules for cutting off PoE power supply of the selected ports within specified time periods. For example, you can customize daytime and nighttime power-saving rules.
Advanced Mode	<p>Set low-priority ports, high-priority ports, and their respective battery thresholds.</p> <ul style="list-style-type: none"> <li>● When the battery percentage is higher than both battery thresholds, PoE power supply of the ports will be cut off within specified time periods according to basic power-saving rules.</li> <li>● When the battery percentage is lower than or equal to the battery threshold for low-priority ports but higher than that for high-priority ports, PoE power supply of low-priority ports will be cut off.</li> <li>● When the battery percentage is lower than or equal to the battery threshold for high-priority ports, PoE power supply of high-priority ports will be cut off.</li> </ul>
Low Power Mode	With low power mode enabled, the device will automatically enter a low-power state when ports are idle (no data transmission) and all indicators except the PWR indicator will be unlit, reducing power consumption.

## 5.2 On Web Page

The device also supports remote management via web page, supporting functions such as activation and login, device overview, network configuration, device configuration, system maintenance, etc., as well as power saving configuration.

For details, please refer to the Web user manual of the device at <http://enpinfodata.hikvision.com/analysisQR/showQR/c7b83365> or scan the QR code below.



Table 5-4 Web User Manual